

TYPES SN54145, SN54LS145, SN74145, SN74LS145 BCD-TO-DECIMAL DECODERS/DRIVERS

MARCH 1974—REVISED DECEMBER 1983

FOR USE AS LAMP, RELAY, OR MOS DRIVERS

- Full Decoding of Input Logic
- SN54145, SN74145, and SN74LS145 Have 80-mA Sink-Current Capability
- All Outputs Are Off for Invalid BCD Input Conditions
- Low Power Dissipation of 'LS145 ... 35 mW Typical

SN54145, SN54LS145 ... J OR W PACKAGE
SN74145 ... J OR N PACKAGE
SN74LS145 ... D, J OR N PACKAGE

(TOP VIEW)

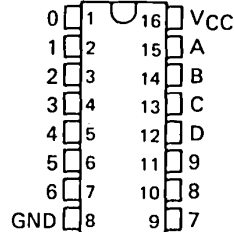

SN54LS145 ... FK PACKAGE
SN74LS145 ... FN PACKAGE

(TOP VIEW)

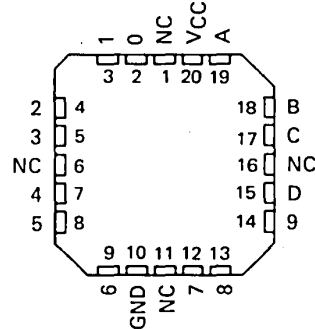

NC - No internal connection

logic

FUNCTION TABLE

NO.	INPUTS				OUTPUTS										
	D	C	B	A	0	1	2	3	4	5	6	7	8	9	
0	L	L	L	L	L	H	H	H	H	H	H	H	H	H	H
1	L	L	L	H	H	L	H	H	H	H	H	H	H	H	H
2	L	L	H	L	H	H	L	H	H	H	H	H	H	H	H
3	L	L	H	H	H	H	H	L	H	H	H	H	H	H	H
4	L	H	L	L	H	H	H	H	L	H	H	H	H	H	H
5	L	H	L	H	H	H	H	H	H	L	H	H	H	H	H
6	L	H	H	L	H	H	H	H	H	H	L	H	H	H	H
7	L	H	H	H	H	H	H	H	H	H	H	L	H	H	H
8	H	L	L	L	H	H	H	H	H	H	H	H	L	H	H
9	H	L	L	H	H	H	H	H	H	H	H	H	H	L	H
INVALID	H	L	H	L	H	H	H	H	H	H	H	H	H	H	H
	H	L	H	H	H	H	H	H	H	H	H	H	H	H	H
	H	H	L	L	H	H	H	H	H	H	H	H	H	H	H
	H	H	L	H	H	H	H	H	H	H	H	H	H	H	H
	H	H	H	L	H	H	H	H	H	H	H	H	H	H	H

H = high level (off), L = low level (on)

description

These monolithic BCD-to-decimal decoder/drivers consist of eight inverters and ten four-input NAND gates. The inverters are connected in pairs to make BCD input data available for decoding by the NAND gates. Full decoding of valid BCD input logic ensures that all outputs remain off for all invalid binary input conditions. These decoders feature high-performance, n-p-n output transistors designed for use as indicator/relay drivers or as open-collector logic-circuit drivers. Each of the high-breakdown output transistors (15 volts) of the SN54145, SN74145, or SN74LS145 will sink up to 80 milliamperes of current. Each input is one Series 54/74 or Series 54LS/74LS standard load, respectively. Inputs and outputs are entirely compatible for use with TTL or DTL logic circuits, and the outputs are compatible for interfacing with most MOS integrated circuits. Power dissipation is typically 215 milliwatts for the '145 and 35 milliwatts for the 'LS145.

logic diagram

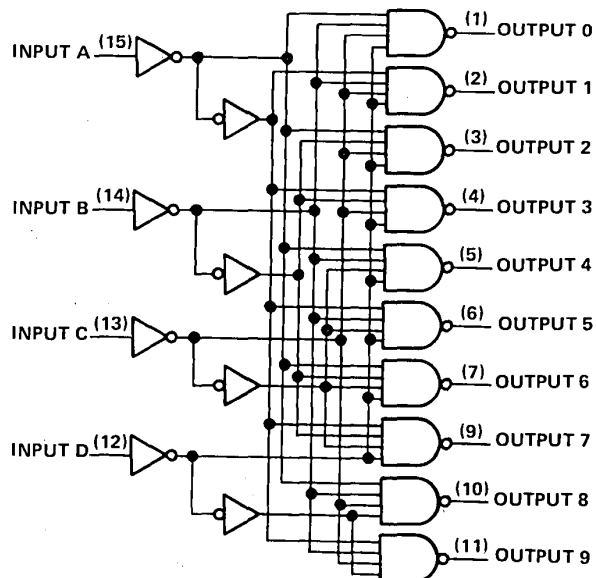

Pin numbers shown on logic notation are for D, J or N packages.

PRODUCTION DATA

This document contains information current as of publication date. Products conform to specifications per the terms of Texas Instruments standard warranty. Production processing does not necessarily include testing of all parameters.

3-552

TEXAS
INSTRUMENTS

POST OFFICE BOX 225012 • DALLAS, TEXAS 75265

3

TTL DEVICES

TYPES SN54LS145, SN74LS145 BCD-TO-DECIMAL DECODERS/DRIVERS

absolute maximum ratings over operating free-air temperature range (unless otherwise noted)

Supply voltage, V_{CC} (see Note 1)	7 V
Input voltage	5.5 V
Maximum current into any output (off-state)	1 mA
Operating free-air temperature range: SN54145	-55°C to 125°C
SN74145	0°C to 70°C
Storage temperature range	-65°C to 150°C

NOTE 1: Voltage values are with respect to network ground terminal.

recommended operating conditions

	SN54145			SN74145			UNIT
	MIN	NOM	MAX	MIN	NOM	MAX	
Supply voltage, V_{CC}	4.5	5	5.5	4.75	5	5.25	V
Off-state output voltage, $V_{O(off)}$			15			15	V
Operating free-air temperature, T_A	-55		125	0		70	°C

electrical characteristics over recommended operating free-air temperature range (unless otherwise noted)

PARAMETER	TEST CONDITIONS†	MIN	TYP‡	MAX	UNIT
V_{IH} High-level input voltage			2		V
V_{IL} Low-level input voltage				0.8	V
V_{IK} Input clamp voltage	$V_{CC} = \text{MIN}, I_I = -12 \text{ mA}$			-1.5	V
$I_{O(off)}$ Off-state output current	$V_{CC} = \text{MIN}, V_{IH} = 2 \text{ V}, V_{IL} = 0.8 \text{ V}, V_{O(off)} = 15 \text{ V}$			250	μA
$V_{O(on)}$ On-state output voltage	$V_{CC} = \text{MIN}, V_{IH} = 2 \text{ V}, V_{IL} = 0.8 \text{ V}$	$I_{O(on)} = 80 \text{ mA}$	0.5	0.9	V
		$I_{O(on)} = 20 \text{ mA}$		0.4	
I_I Input current at maximum input voltage	$V_{CC} = \text{MAX}, V_I = 5.5 \text{ V}$			1	mA
I_{IH} High-level input current	$V_{CC} = \text{MAX}, V_I = 2.4 \text{ V}$			40	μA
I_{IL} Low-level input current	$V_{CC} = \text{MAX}, V_I = 0.4 \text{ V}$			-1.6	mA
I_{CC} Supply current	$V_{CC} = \text{MAX}, \text{ See Note 2}$	SN54145	43	62	mA
		SN74145	43	70	

† For conditions shown as MIN or MAX, use the appropriate value specified under recommended operating conditions.

‡ All typical values are at $V_{CC} = 5 \text{ V}, T_A = 25^\circ\text{C}$.

NOTE 2: I_{CC} is measured with all inputs grounded and outputs open.

switching characteristics, $V_{CC} = 5 \text{ V}, T_A = 25^\circ\text{C}$

PARAMETER	TEST CONDITIONS	MIN	MAX	UNIT
t_{PLH} Propagation delay time, low-to-high-level output	$C_L = 15 \text{ pF}, R_L = 100 \Omega, \text{ See Note 3}$		50	ns
t_{PHL} Propagation delay time, high-to-low-level output			50	ns

NOTE 3: See General Information Section for load circuits and voltage waveforms.

schematics of inputs and outputs

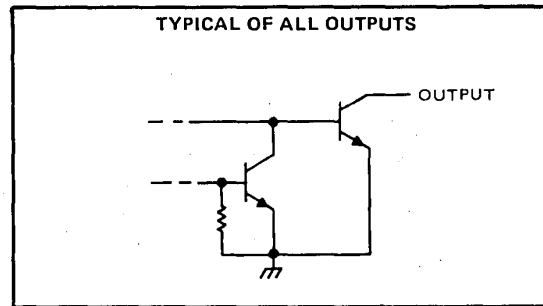
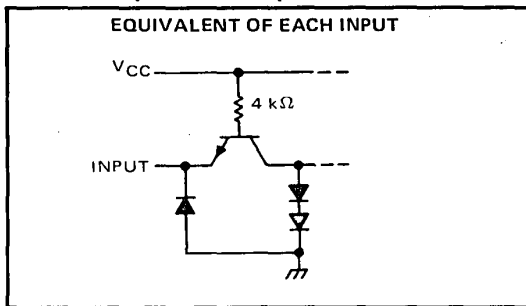

3
TTL DEVICES

TYPES SN54145, SN74145 BCD-TO-DECIMAL DECODERS/DRIVERS

absolute maximum ratings over operating free-air temperature range (unless otherwise noted)

Supply voltage, V_{CC} (see Note 1)	7 V
Input voltage	7 V
Operating free-air temperature range: SN54LS145	-55°C to 125°C
SN74LS145	0°C to 70°C
Storage temperature range	-65°C to 150°C

NOTE 1: Voltage values are with respect to network ground terminal.

recommended operating conditions

	SN54LS145			SN74LS145			UNIT	
	MIN	NOM	MAX	MIN	NOM	MAX		
Supply voltage, V_{CC}	4.5	5	5.5	4.75	5	5.25	V	
Off-state output voltage, $V_{O(off)}$	15			15			V	
Operating free-air temperature, T_A	-55			0			70	°C

electrical characteristics over recommended operating free-air temperature range (unless otherwise noted)

PARAMETER	TEST CONDITIONS†	SN54LS145		SN74LS145		UNIT	
		MIN	TYP‡	MAX	MIN		TYP‡
V_{IH} High-level input voltage		2		2		V	
V_{IL} Low-level input voltage		0.7		0.8		V	
V_{IK} Input clamp voltage	$V_{CC} = \text{MIN}, I_I = -18 \text{ mA}$	-1.5		-1.5		V	
$I_{O(off)}$ Off-state output current	$V_{CC} = \text{MIN}, V_{IH} = 2 \text{ V}, V_{IL} = V_{IL \text{ max}}, V_{OH} = 15 \text{ V}$	250		250		μA	
$V_{O(on)}$ On-state output voltage	$V_{CC} = \text{MIN}, V_{IH} = 2 \text{ V}, V_{IL} = V_{IL \text{ max}}$	$I_{OL} = 12 \text{ mA}$	0.25	0.4	0.25	0.4	V
		$I_{OL} = 24 \text{ mA}$			0.35	0.5	
		$I_{OL} = 80 \text{ mA}$			2.3	3	
I_I Input current at maximum input voltage	$V_{CC} = \text{MAX}, V_I = 7 \text{ V}$	0.1		0.1		mA	
I_{IH} High-level input current	$V_{CC} = \text{MAX}, V_I = 2.7 \text{ V}$	20		20		μA	
I_{IL} Low-level input current	$V_{CC} = \text{MAX}, V_I = 0.4 \text{ V}$	-0.4		-0.4		mA	
I_{CC} Supply current	$V_{CC} = \text{MAX},$ See Note 2	7	13	7	13	mA	

† For conditions shown as MIN or MAX, use the appropriate value specified under recommended operating conditions.

‡ All typical values are at $V_{CC} = 5 \text{ V}, T_A = 25^\circ\text{C}$.

NOTE 2: I_{CC} is measured with all inputs grounded and outputs open.

switching characteristics, $V_{CC} = 5 \text{ V}, T_A = 25^\circ\text{C}$

PARAMETER	TEST CONDITIONS	MIN	MAX	UNIT
t_{PLH} Propagation delay time, low-to-high-level output	$C_L = 45 \text{ pF}, R_L = 665 \Omega,$ See Note 3	50		ns
t_{PHL} Propagation delay time, high-to-low-level output		50		ns

NOTE 3: See General Information Section for load circuits and voltage waveforms.

schematic of inputs and outputs

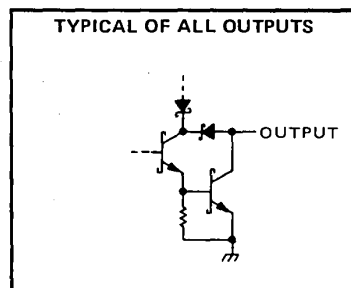
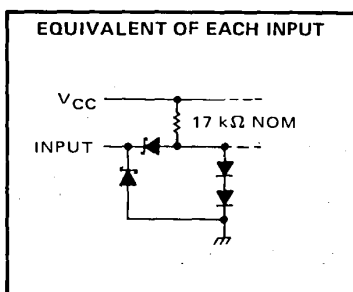

3

TTL DEVICES