

TYPES SN54104, SN54105, SN74104, SN74105 GATED J-K MASTER-SLAVE FLIP-FLOPS

REVISED DECEMBER 1983

- Buffered Clock Input
- Direct Preset and Clear
- Common JK Gate Input

logic

FUNCTION TABLE

INPUT AT t_n			OUTPUT AT t_{n+1}	
JK	J \dagger	K \dagger	Q	\bar{Q}
L \dagger	X	X	Q_n	\bar{Q}_n
H	L \dagger	L \dagger	Q_n	\bar{Q}_n
H	L	H	L	H
H	H	L	H	L
H	H	H	\bar{Q}_n	Q_n

\dagger SN54104/SN74104J = J1 · J2 · J3.

K = K1 · K2 · K3

SN54105/SN74105J = J1 · $\bar{J}2$ · J3.

K = K1 · K2 · K3

\dagger These low-levels must be maintained while the clock is low.

NOTES:

- t_n = bit time before clock pulse
- t_{n+1} = bit time after clock pulse
- H = high, L = low, X = irrelevant

SN54104 . . . J OR W PACKAGE
SN74104 . . . J OR N PACKAGE

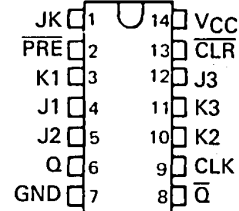

SN54105 . . . J OR W PACKAGE
SN74105 . . . J OR N PACKAGE

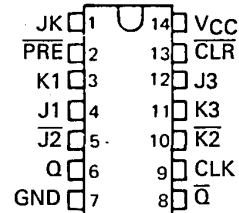

description

These J-K master-slave flip-flops feature a buffered clock input, direct preset and clear, gated J and K inputs, and a common JK input. The clock buffer offers typical TTL high noise immunity, low clock-line loading, and, in most cases, eliminates the need for stringent control of system-clock rise and fall times. When activated, the direct preset and clear inputs control the state of both the master and slave flip-flops independent of the clock and synchronous-input states. Gated inputs may be used to perform a wide variety of control functions without the need for external gates, and the common JK input simplifies hardware design for applications utilizing a single gate-control source.

Due to the internal clock buffer, the JK input gates accept data when the clock line is low, and transfer of data from the master to the slave occurs during the clock-line transition from the low state to the high state. When the clock line is high, the data inputs are inhibited.

The SN54104/SN74104 includes internal capacitive loading on the J and K input gates and, as the input setup and hold times are lengthened, this circuit displays improved performance in systems where appreciable clock skew is anticipated.

The SN54105/SN74105 offers an inverting data input to each of the J and K input gates for additional control flexibility. As the input setup and hold times are not lengthened, this circuit permits operation at higher toggle rates than the SN54104/SN74104.

These TTL circuits feature one-volt typical d-c noise margins and are compatible for use with most TTL families. Full fan-out to 10 normalized Series 54/74 loads is available from the outputs. The SN54104 and SN54105 circuits are characterized for operation over the full military temperature range of -55°C to 125°C , and the SN74104 and SN74105 circuits are characterized for operation from 0°C to 70°C .

PRODUCTION DATA

This document contains information current as of publication date. Products conform to specifications per the terms of Texas Instruments standard warranty. Production processing does not necessarily include testing of all parameters.

TEXAS
INSTRUMENTS

POST OFFICE BOX 225012 • DALLAS, TEXAS 75265

3-419

3

TTL DEVICES

TYPES SN54104, SN54105, SN74104, SN74105

GATED J-K MASTER-SLAVE FLIP-FLOPS

logic diagrams

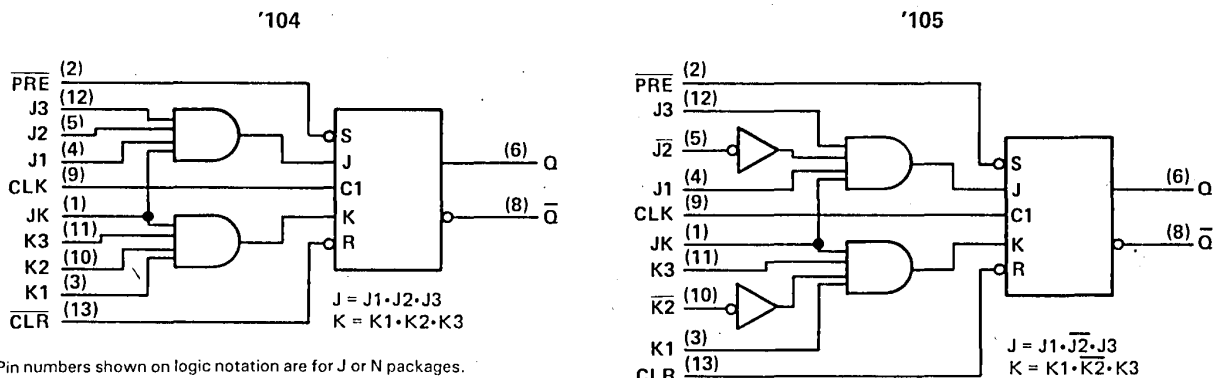

Pin numbers shown on logic notation are for J or N packages.

absolute maximum ratings over operating free-air temperature range (unless otherwise noted)

Supply voltage, V_{CC} (See Note 1)	8 V
Input voltage	5.5 V
Voltage applied to any output (See Note 2)	5.5 V
Operating free-air temperature range: SN54104, SN54105 Circuits	-55°C to 125°C
SN74104, SN74105 Circuits	0°C to 70°C
Storage temperature range	-65°C to 150°C

recommended operating conditions

		SN54'			SN74'			UNIT
		MIN	NOM	MAX	MIN	NOM	MAX	
V_{CC}	Supply voltage (see Note 1)	4.5	5	5.5	4.75	5	5.25	V
V_{IH}	High-level input voltage	2			2			V
V_{IL}	Low-level input voltage			0.8			0.8	V
I_{OH}	High-level output current			-1			-1	mA
I_{OL}	Low-level output current			16			16	mA
t_w	Pulse duration	CLK Low-level	15 [†]		15 [†]			ns
		PRE and CLR	20 [†]		20 [†]			
t_{su}	Setup time for high-level data (See Note 4)	'104	35 [†]		35 [†]			ns
		'105	10 [†]		10 [†]			
t_r	Release time for low-level data (See Note 3)	'104		10 [†]		10 [†]		ns
		'105		1 [†]		1 [†]		
T_A	Operating free-air temperature	-55		125	0		70	$^{\circ}\text{C}$

[†] These conditions are recommended at $V_{CC} = 5\text{ V}$, $T_A = 25^{\circ}\text{C}$.

- NOTES: 1. Voltage values are with respect to network ground terminal.
 2. This rating applied at the Q output with preset held low and at the \bar{Q} output with clear held low.
 3. Release time for low-level data is an interval between the release of low-level data and the positive-going edge of the clock pulse; this interval being sufficiently short to ensure recognition of the low-level data.
 4. Setup time for high-level data is an interval between the arrival of the high-level data and the positive-going edge of the clock pulse; this interval being sufficiently long to ensure recognition of the high-level data.

TYPES SN54104, SN54105, SN74104, SN74105
GATED J-K MASTER-SLAVE FLIP-FLOPS

electrical characteristics over recommended operating free-air temperature range (unless otherwise noted)

PARAMETER		TEST CONDITIONS†	MIN	TYP‡	MAX	UNIT
V _{OH}		V _{CC} = MIN, I _{OH} = -1 mA	2.4	2.7		V
V _{OL}		V _{CC} = MIN, I _{OL} = 16 mA		0.2	0.4	V
I _{IH}	PRE or CLR	V _{CC} = MAX, V _I = 4.5 V		8	120	μA
	J or K			4	80	
	All other			2	40	
I _{IL}	PRE or CLR	V _{CC} = MAX, V _I = 0.4 V		-3	-4.75	mA
	J or K			-2.2	-3.2	
	All other			-1.1	-1.6	
I _{CC}	'104	V _{CC} = 5 V		15	24	mA
	'105			17	28	

† For conditions shown as MIN or MAX, use appropriate value specified under recommended operating conditions for the applicable device type.

‡ All typical values are at V_{CC} = 5 V, T_A = 25°C.

switching characteristics, V_{CC} = 5 V, T_A = 25°C (see note 5)

PARAMETER	FROM (INPUT)	TO (OUTPUT)	TEST CONDITIONS	MIN	TYP	MAX	UNIT
t _{PLH}	CLK	Q or Q̄	R _L = 400 Ω, C _L = 15 pF		9	15	ns
t _{PHL}					16	25	

NOTE 5: See General Information Section for load circuits and voltage waveforms.