

TYPES SN5412, SN54LS12 SN7412, SN74LS12

TRIPLE 3-INPUT POSITIVE-NAND GATES WITH OPEN-COLLECTOR OUTPUTS

REVISED DECEMBER 1983

- Package Options Include Both Plastic and Ceramic Chip Carriers in Addition to Plastic and Ceramic DIPs
- Dependable Texas Instruments Quality and Reliability

description

These devices contain three independent 3-input NAND gates with open-collector outputs. The open-collector outputs require pull-up resistors to perform correctly. They may be connected to other open-collector outputs to implement active-low wired-OR or active-high wired-AND functions. Open-collector devices are often used to generate higher V_{OH} levels.

The SN5412 and SN54LS12 are characterized for operation over the full military range of -55°C to 125°C . The SN7412 and SN74LS12 are characterized for operation from 0°C to 70°C .

FUNCTION TABLE (each gate)

INPUTS			OUTPUT
A	B	C	Y
H	H	H	L
L	X	X	H
X	L	X	H
X	X	L	H

logic diagram (each gate)



positive logic

$$Y = \overline{A \cdot B \cdot C} \text{ or } Y = \overline{A} + \overline{B} + \overline{C}$$

SN5412, SN54LS12 ... J OR W PACKAGE
SN7412 ... J OR N PACKAGE
SN74LS12 ... D, J OR N PACKAGE
(TOP VIEW)

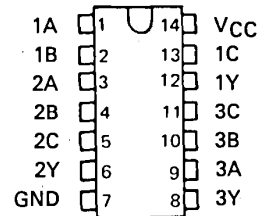

SN54LS12 ... FK PACKAGE
SN74LS12 ... FN PACKAGE
(TOP VIEW)

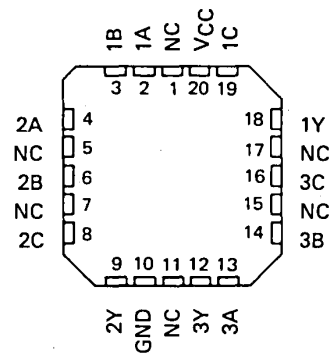

NC - No internal connection



TTL DEVICES

TYPES SN5412, SN54LS12
SN7412, SN74LS12

TRIPLE 3-INPUT POSITIVE-NAND GATES WITH OPEN-COLLECTOR OUTPUTS

schematics (each gate)

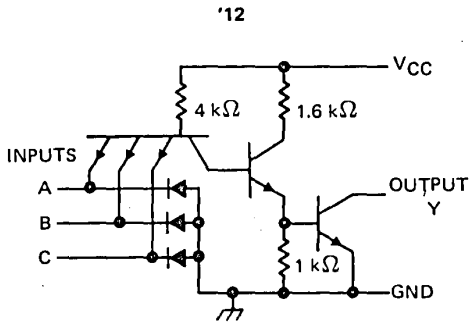

Resistor values shown are nominal.

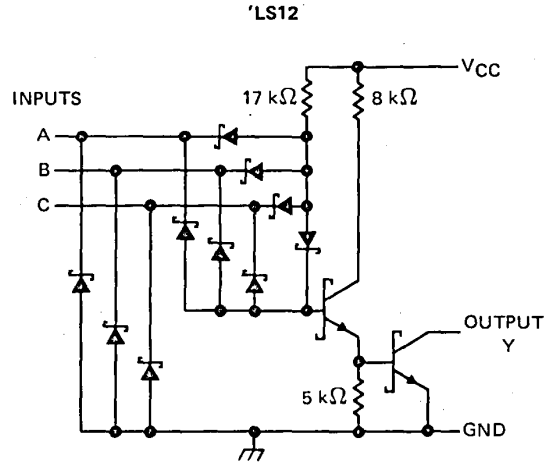

absolute maximum ratings over operating free-air temperature range (unless otherwise noted)

Supply voltage, V_{CC} (see Note 1)	7 V
Input voltage: '12	5.5 V
'LS12	7 V
Off-state output voltage	7 V
Operating free-air temperature: SN54'	-55°C to 125°C
SN74'	0°C to 70°C
Storage temperature range	-65°C to 150°C

NOTE 1: Voltage values are with respect to network ground terminal.



TTL DEVICES

TYPES SN5412, SN7412
TRIPLE 3-INPUT POSITIVE-NAND GATES WITH OPEN-COLLECTOR OUTPUTS

recommended operating conditions

	SN5412			SN7412			UNIT
	MIN	NOM	MAX	MIN	NOM	MAX	
V _{CC} Supply voltage	4.5	5	5.5	4.75	5	5.25	V
V _{IH} High-level input voltage	2			2			V
V _{IL} Low-level input voltage	0.8			0.8			V
V _{OH} High-level output voltage	5.5			5.5			V
I _{OL} Low-level output current	16			16			mA
T _A Operating free-air temperature	-55 125			0 70			°C

electrical characteristics over recommended operating free-air temperature range (unless otherwise noted)

PARAMETER	TEST CONDITIONS†	MIN	TYP‡	MAX	UNIT
V _{IK}	V _{CC} = MIN, I _I = -12 mA			-1.5	V
I _{OH}	V _{CC} = MIN, V _{IL} = 0.8 V, V _{OH} = 5.5 V			0.25	mA
V _{OL}	V _{CC} = MIN, V _{IH} = 2 V, I _{OL} = 16 mA		0.2	0.4	V
I _I	V _{CC} = MAX, V _I = 5.5 V			1	mA
I _{IH}	V _{CC} = MAX, V _I = 2.4 V			40	μA
I _{IL}	V _{CC} = MAX, V _I = 0.4 V			-1.6	mA
I _{CCH}	V _{CC} = MAX, V _I = 0 V		3	6	mA
I _{CCL}	V _{CC} = MAX, V _I = 4.5 V		9	16.5	mA

† For conditions shown as MIN or MAX, use the appropriate value specified under recommended operating conditions.

‡ All typical values are at V_{CC} = 5 V, T_A = 25°C.

switching characteristics, V_{CC} = 5 V, T_A = 25°C (see note 2)

PARAMETER	FROM (INPUT)	TO (OUTPUT)	TEST CONDITIONS	MIN	TYP	MAX	UNIT
t _{PLH}	A, B or C	Y	R _L = 4 kΩ, C _L = 15 pF	35	45		ns
t _{PHL}			R _L = 400 Ω, C _L = 15 pF	8	15		ns

NOTE 2: See General Information Section for load circuits and voltage waveforms.

3 TTL DEVICES

TYPES SN54LS12, SN74LS12 TRIPLE 3-INPUT POSITIVE-NAND GATES WITH OPEN-COLLECTOR OUTPUTS

recommended operating conditions

	SN54LS12			SN74LS12			UNIT
	MIN	NOM	MAX	MIN	NOM	MAX	
V_{CC} Supply voltage	4.5	5	5.5	4.75	5	5.25	V
V_{IH} High-level input voltage	2			2			V
V_{IL} Low-level input voltage			0.7			0.8	V
V_{OH} High-level output voltage			5.5			5.5	V
I_{OL} Low-level output current			4			8	mA
T_A Operating free-air temperature	-55		125	0		70	°C

electrical characteristics over recommended operating free-air temperature range (unless otherwise noted)

PARAMETER	TEST CONDITIONS†	SN54LS12		SN74LS12		UNIT	
		MIN	TYP‡	MAX	MIN		TYP‡
V_{IK}	$V_{CC} = \text{MIN}, I_I = -18 \text{ mA}$			-1.5		-1.5	V
I_{OH}	$V_{CC} = \text{MIN}, V_{IL} = \text{MAX}, V_{OH} = 5.5 \text{ V}$			0.1		0.1	mA
V_{OL}	$V_{CC} = \text{MIN}, V_{IH} = 2 \text{ V}, I_{OL} = 4 \text{ mA}$			0.25		0.4	V
	$V_{CC} = \text{MIN}, V_{IH} = 2 \text{ V}, I_{OL} = 8 \text{ mA}$					0.35	
I_I	$V_{CC} = \text{MAX}, V_I = 7 \text{ V}$			0.1		0.1	mA
I_{IH}	$V_{CC} = \text{MAX}, V_I = 2.7 \text{ V}$			20		20	μA
I_{IL}	$V_{CC} = \text{MAX}, V_I = 0.4 \text{ V}$			-0.4		-0.4	mA
I_{CCH}	$V_{CC} = \text{MAX}, V_I = 0 \text{ V}$			0.7		1.4	mA
I_{CCL}	$V_{CC} = \text{MAX}, V_I = 4.5 \text{ V}$			1.8		3.3	mA

† For conditions shown as MIN or MAX, use the appropriate value specified under recommended operating conditions.

‡ All typical values are at $V_{CC} = 5 \text{ V}, T_A = 25^\circ\text{C}$.

switching characteristics, $V_{CC} = 5 \text{ V}, T_A = 25^\circ\text{C}$ (see note 2)

PARAMETER	FROM (INPUT)	TO (OUTPUT)	TEST CONDITIONS	MIN	TYP	MAX	UNIT
t_{PLH}	A, B or C	Y	$R_L = 2 \text{ k}\Omega, C_L = 15 \text{ pF}$		17	32	ns
t_{PHL}					15	28	ns

NOTE 2: See General Information Section for load circuits and voltage waveforms.

3

TTL DEVICES