

# TYPES SN54LS171, SN74LS171 QUADRUPLE D-TYPE FLIP-FLOPS WITH CLEAR

REVISED DECEMBER 1983

- Contains Four Flip-Flops with Double Rail Outputs
- Buffered Clock and Clear Inputs
- Individual Data Inputs to Each Flip-Flop

## description

These monolithic, positive-edge triggered flip-flops utilize the latest low-power Schottky circuitry to implement D-type flip-flop logic. They have a direct clear input and complementary outputs from each flip-flop.

Information at the D inputs meeting the setup time requirements is transferred to the Q outputs on the positive-going edge of the clock pulse. Clock triggering occurs at a particular voltage level and is not directly related to the transition time of the positive going pulse. When the clock input is at either the high or low level, the D input signal has no effect at the output.

## logic diagram

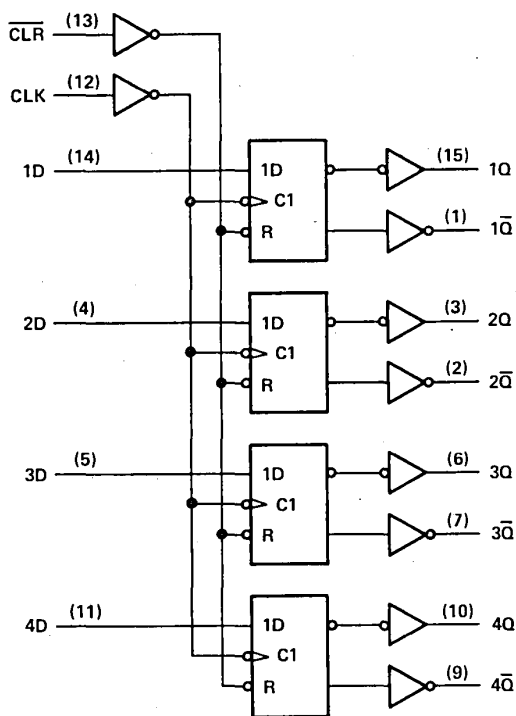

Pin numbers shown on logic notation are for D, J or N packages.

SN54LS171 ... J OR W PACKAGE  
SN74LS171 ... D, J OR N PACKAGE  
(TOP VIEW)

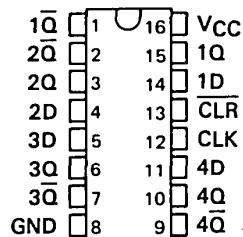

SN54LS171 ... FK PACKAGE  
SN74LS171 ... FN PACKAGE  
(TOP VIEW)

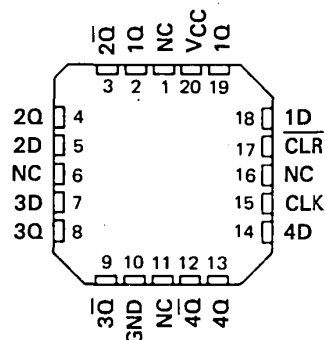

NC-No internal connection

FUNCTION TABLE  
(EACH FLIP-FLOP)

INPUTS			OUTPUTS	
CLR	CLK	D	Q	Q̄
L	X	X	L	H
H	↑	H	H	L
H	↑	L	L	H
H	L	X	Q <sub>0</sub>	Q̄ <sub>0</sub>

**PRODUCTION DATA**  
This document contains information current as of publication date. Products conform to specifications per the terms of Texas Instruments standard warranty. Production processing does not necessarily include testing of all parameters.

**TEXAS INSTRUMENTS**  
POST OFFICE BOX 225012 • DALLAS, TEXAS 75265

3-675



TTL DEVICES

# TYPES SN54LS171, SN74LS171 QUADRUPLE D-TYPE FLIP-FLOPS WITH CLEAR

## schematics of inputs and outputs

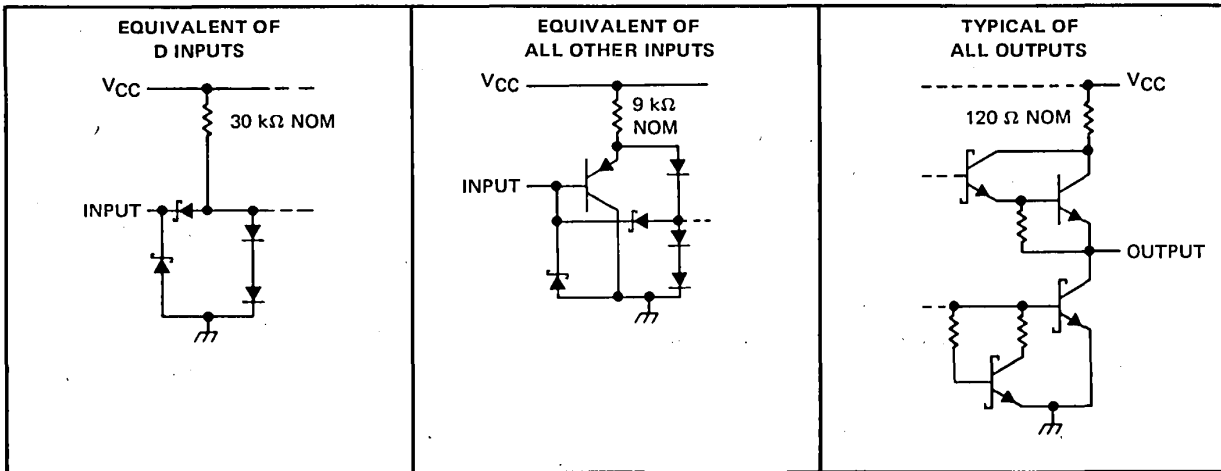

## absolute maximum ratings over operating free-air temperature range (unless otherwise noted)

Supply voltage, $V_{CC}$ (See Note 1) .....	7 V
Input voltage .....	7 V
Operating free-air temperature range: SN54LS171 Circuits .....	-55°C to 125°C
SN74LS171 Circuits .....	0°C to 70°C
Storage temperature range .....	-65°C to 150°C

NOTE 1: Voltage values are with respect to network ground terminal.

## recommended operating conditions

	SN54LS171			SN74LS171			UNIT
	MIN	NOM	MAX	MIN	NOM	MAX	
$V_{CC}$ Supply voltage	4.5	5	5.5	4.75	5	5.25	V
$V_{IH}$ High-level input voltage	2			2			V
$V_{IL}$ Low-level input voltage	0.7			0.8			V
$I_{OH}$ High-level output current	-0.4			-0.4			mA
$I_{OL}$ Low-level output current	4			8			mA
$f_{clock}$ Clock frequency	0		20	0		20	MHz
$t_w$ Width of clock or clear pulse	20			20			ns
$t_{su}$ Setup time	Data input		20	Data input		20	ns
	Clear inactive-state		25	Clear inactive-state		25	
$t_h$ Data hold time	5			5			ns
$T_A$ Operating free-air temperature	-55		125	0		70	°C

3

TTL DEVICES

## TYPES SN54LS171, SN74LS171 QUADRUPLE D-TYPE FLIP-FLOPS WITH CLEAR

electrical characteristics over recommended operating free-air temperature range (unless otherwise noted)

PARAMETER	TEST CONDITIONS†	SN54LS171		SN74LS171		UNIT		
		MIN	TYP‡	MAX	MIN		TYP‡	MAX
$V_{IK}$ Input clamp voltage	$V_{CC} = \text{MIN}, I_I = -18 \text{ mA}$			-1.5		-1.5	V	
$V_{OH}$ High-level output voltage	$V_{CC} = \text{MIN}, V_{IH} = 2 \text{ V}, V_{IL} = \text{MAX}, I_{OH} = -1 \text{ mA}$	2.5	3.4		2.7	3.4	V	
$V_{OL}$ Low-level output voltage	$V_{CC} = \text{MIN}, V_{IH} = 2 \text{ V}, V_{IL} = \text{MAX}$	$I_{OL} = 4 \text{ mA}$		0.25	0.4	0.25	0.4	
		$I_{OL} = 8 \text{ mA}$				0.35	0.5	
$I_I$ Input current at maximum input voltage	$V_{CC} = \text{MAX}, V_I = 7 \text{ V}$			0.1		0.1	mA	
$I_{IH}$ High-level input current	$V_{CC} = \text{MAX}, V_I = 2.7 \text{ V}$			20		20	$\mu\text{A}$	
$I_{IL}$ Low-level input current	$V_{CC} = \text{MAX}, V_I = 0.4 \text{ V}$	D inputs		-0.4		-0.4	mA	
		All others		-0.2		-0.2	mA	
$I_{OS}§$ Short-circuit output current	$V_{CC} = \text{MAX}, V_O = 0 \text{ V}$	-20		-100	-20	-100	mA	
$I_{CC}$ Supply current	$V_{CC} = \text{MAX},$ See Note 1		14	25		14	25	mA

† For conditions shown as MIN or MAX, use the appropriate value specified under recommended operating conditions.

‡ All typical values are at  $V_{CC} = 5 \text{ V}, T_A = 25^\circ\text{C}$ .

§ Not more than one output should be shorted at a time and the duration of the short-circuit should not exceed one second.

NOTE 1:  $I_{CC}$  is measured with all inputs grounded and all outputs open.

switching characteristics,  $V_{CC} = 5 \text{ V}, T_A = 25^\circ\text{C}$  (see note 2)

PARAMETER	FROM (INPUT)	TO (OUTPUT)	TEST CONDITIONS	'LS171			UNIT	
				MIN	TYP	MAX		
$f_{\text{max}}$			$R_L = 2 \text{ k}\Omega, C_L = 15 \text{ pF}$	20	30		MHz	
$t_{\text{PLH}}$	CLK	Q, $\bar{Q}$			15	25		ns
$t_{\text{PHL}}$					18	30		ns
$t_{\text{PLH}}$				$\overline{\text{CLR}}$	Q		18	30
$t_{\text{PHL}}$		24				40		ns

NOTE 2: See General Information Section for load circuits and voltage waveforms.



TTL DEVICES

  
**TEXAS INSTRUMENTS**

POST OFFICE BOX 225012 • DALLAS, TEXAS 75265

3-677